

Specifications

Steel Slat Straight Back Park Bench

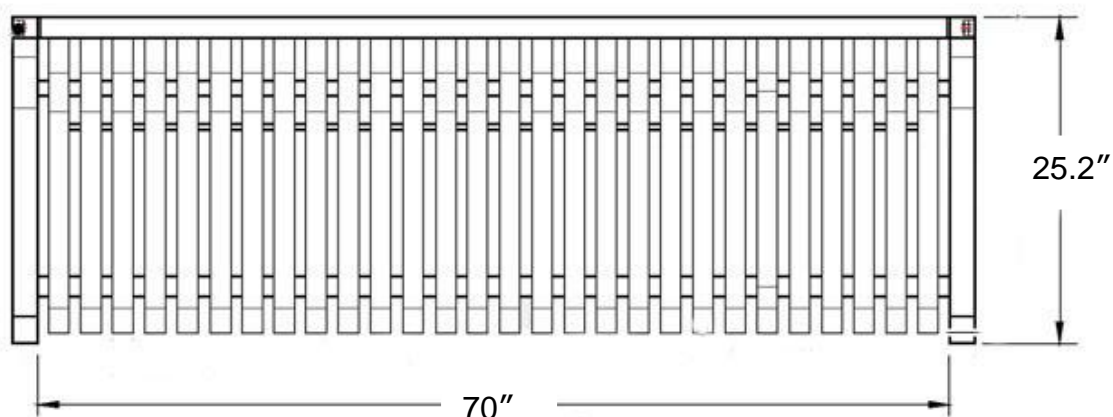

Top view

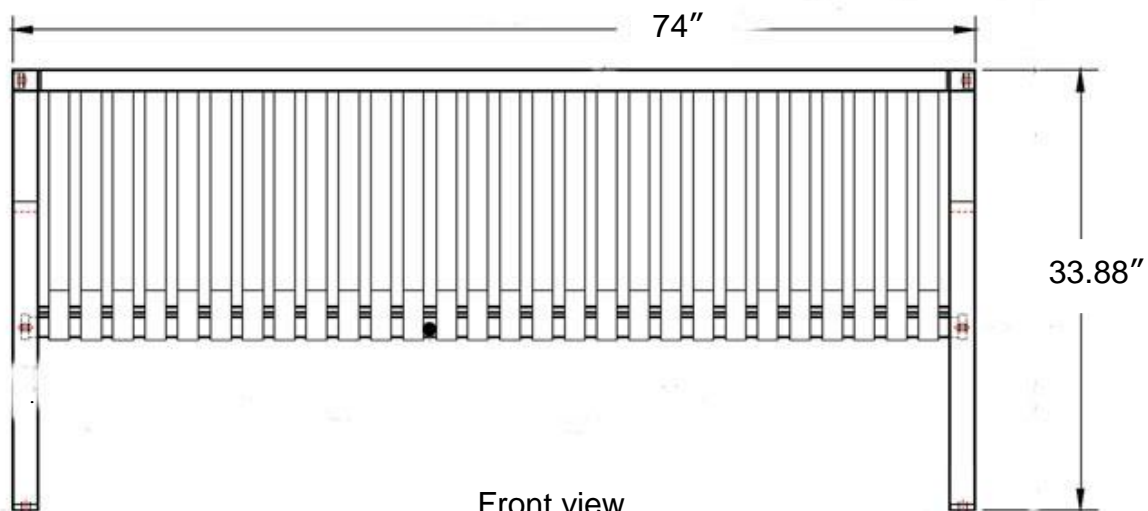

Front view

Length	Width	Height	Seat height	Steel slats
74"	25.2"	33.88"	17 1/2"	Width: 1.57" Thickness: 0.177" Space in between: 0.91"

Material:	Cold rolled carbon steel
Finish:	Black powder coating
Fasteners:	All stainless steel fasteners
Seat Steel Slats:	7 Gauge
Bench End Steel:	0.4" thickness

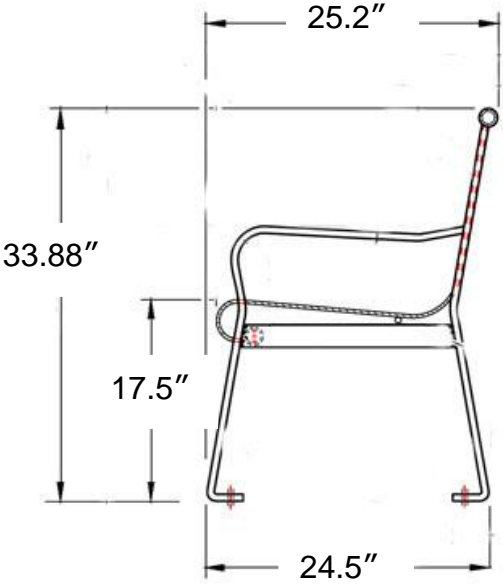

End view

Assembly Instructions

Steel Slat Straight Back Park Bench



Before assembly, please make sure all components & hardware are included.



2 - bench ends

A



B

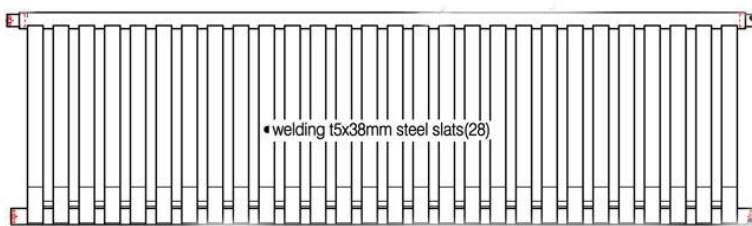

1 - seat assembly – front view

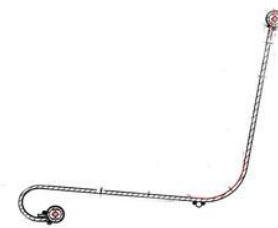

side view

C

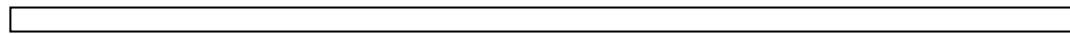

1 – tie bar

6 - 10mm x 28mm hex head bolts

6 - Washers

1 – Wrench

Step 1: Position the packing cardboard to form a protected work surface. Assembly requires two people. Place seat assembly on the cardboard on its backside and attach end frames to each end of the seat assembly at the front using 1 bolt and washer on each side.

Note: Keep all screws loose until bench has been completely assembled.

Step 2: Raise the seat assembly up to align the top holes and attach the end frames to the seat assembly using 1 bolt and washer per hole at the top.

Step 3: Insert the tie bar into the back, bottom of each bench end. Screw in bolts enough to hold securely, but do not tighten. Make sure that the bench is square and level. Tighten all loose bolts to secure.

