



**BRASCO INTERNATIONAL, INC.**

32400 INDUSTRIAL DRIVE  
 MADISON HEIGHTS, MICHIGAN 48071  
 1-800-893-3665 WWW.BRASCO.COM

THIS DRAWING IS CONFIDENTIAL AND IS FOR THE SOLE USE OF OUR CUSTOMERS AND MAY NOT BE REPRODUCED OR COPIED WITHOUT WRITTEN PERMISSION FROM BRASCO INTERNATIONAL. LEAD TIME BEGINS UPON RECEIPT OF SIGNED APPROVAL.

SIGNED: \_\_\_\_\_

DATE: \_\_\_\_\_

CUSTOMER: CITY OF FREDERICKSBURG  
 PROJECT: GLAZED HIP STYLE TRANSIT SHELTER  
 MODEL: SLIMLINE SERIES - SL0408

ENGINEER: RCG  
 DATE: 8-16-17  
 CHECKER: SJT  
 DATE: 8-16-17  
 SHEET #: 5144-1

**PLAN VIEW**

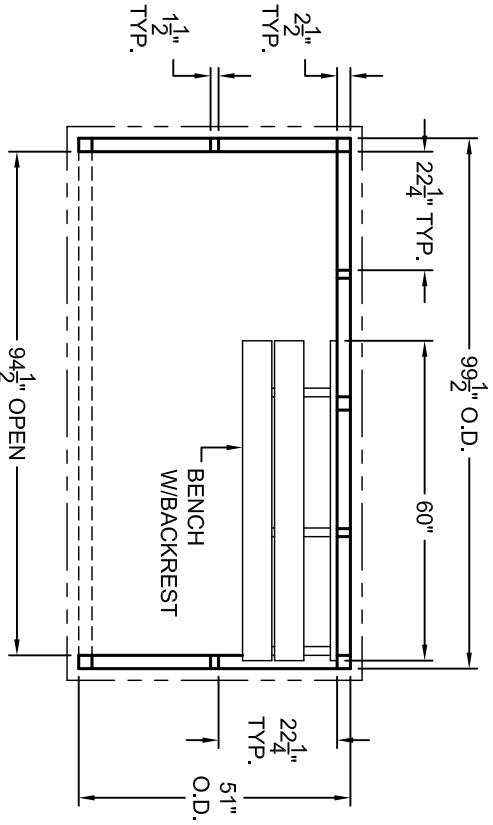

**QUANTITY (1) SHELTER THUS**

**SPECIFICATIONS:**

- DARK BRONZE ANODIZED ALUMINUM STRUCTURE
- 1/4" CLEAR ACRYLIC WALL GLAZING
- BRONZE TWINWALL GLAZED HIP ROOF WITH FASCIA / GUTTER SYSTEM
- PARTIAL LENGTH ALUMINUM BENCH W/ BACKREST
- BLACK 20 GALLON PERFORATED TRASH RECEPTACLE (NOT SHOWN)
- BLACK ASH URN (NOT SHOWN)

**FRONT ELEVATION**

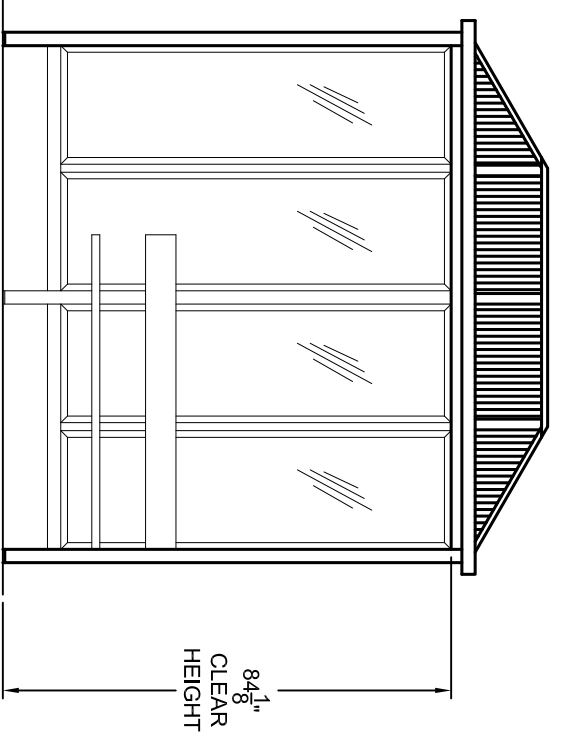

**SIDE ELEVATION**

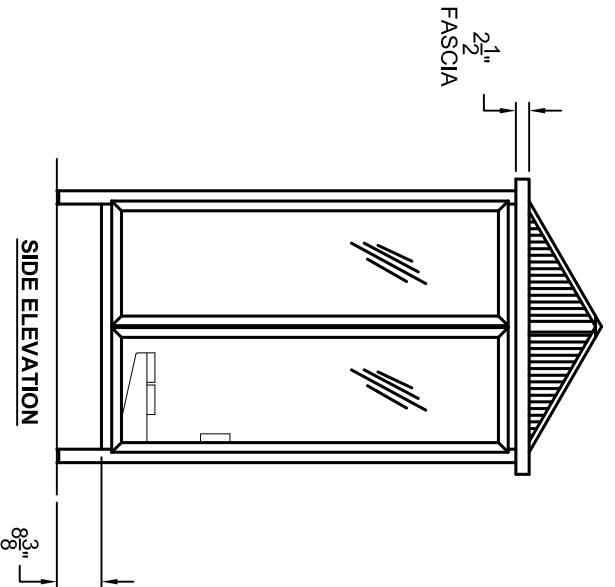

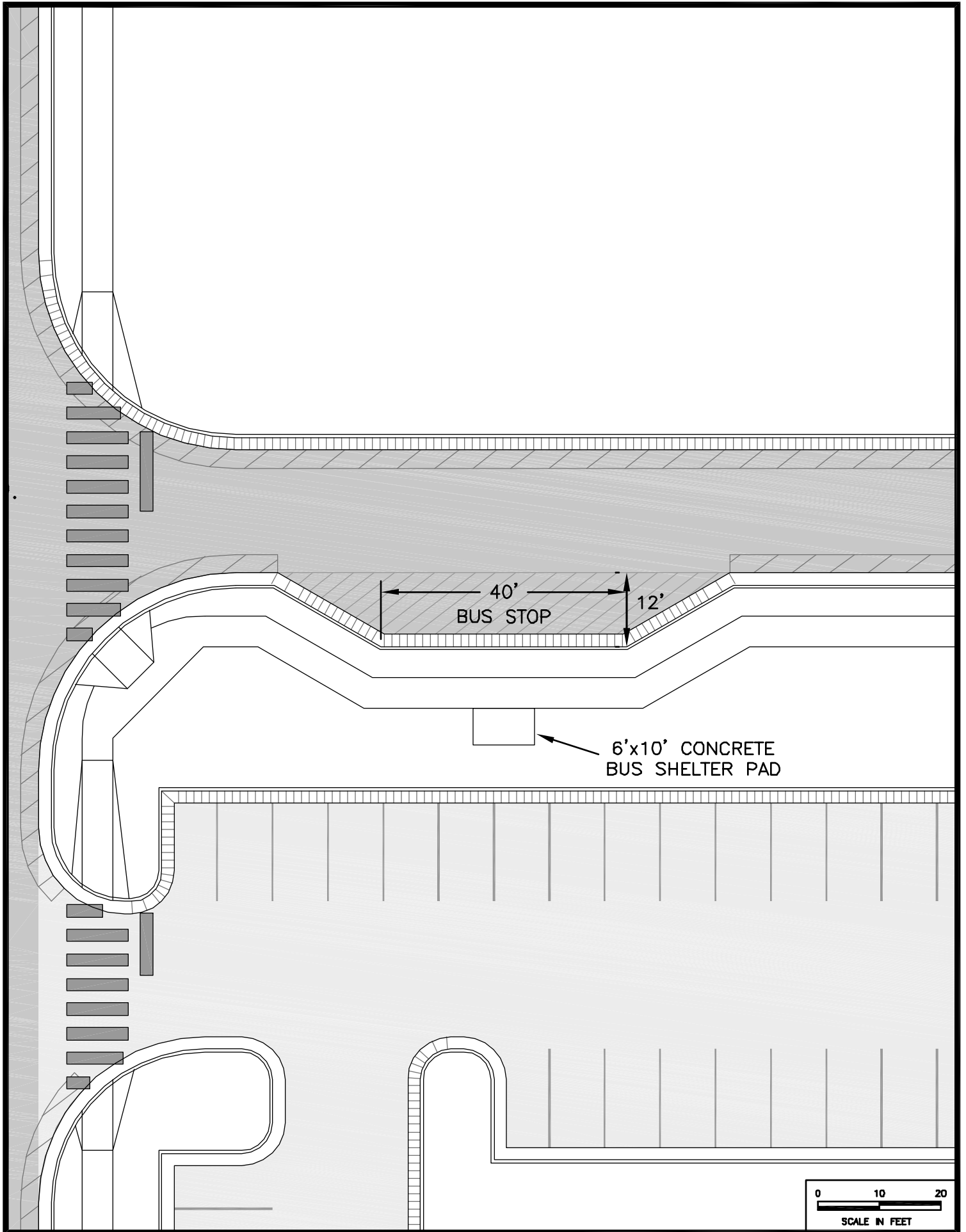

40'  
BUS STOP  
12'

6'x10' CONCRETE  
BUS SHELTER PAD

0 10 20  
SCALE IN FEET